



Kane International Ltd

KANE425

Function Training

Presented by
Gary Fairhurst
Service Training & Support Engineer

Kane International Ltd

Introducing Kane



- Established in 1963 in Welwyn Garden City, UK
- Develops & Manufactures:
 - Gas analysers
 - Gas leak detectors
 - Pressure meters
 - Vehicle exhaust analysers
- R & D is 6% of sales
- Over £6M sales
- 60 staff

Kane International Ltd

The KANE425 is a...



1. Combustion Analyser
2. Differential Pressure Meter
3. Differential Thermometer
4. Ambient CO Analyser
5. Gas Leak Detector
6. Torch

Kane International Ltd

Rotary Switch

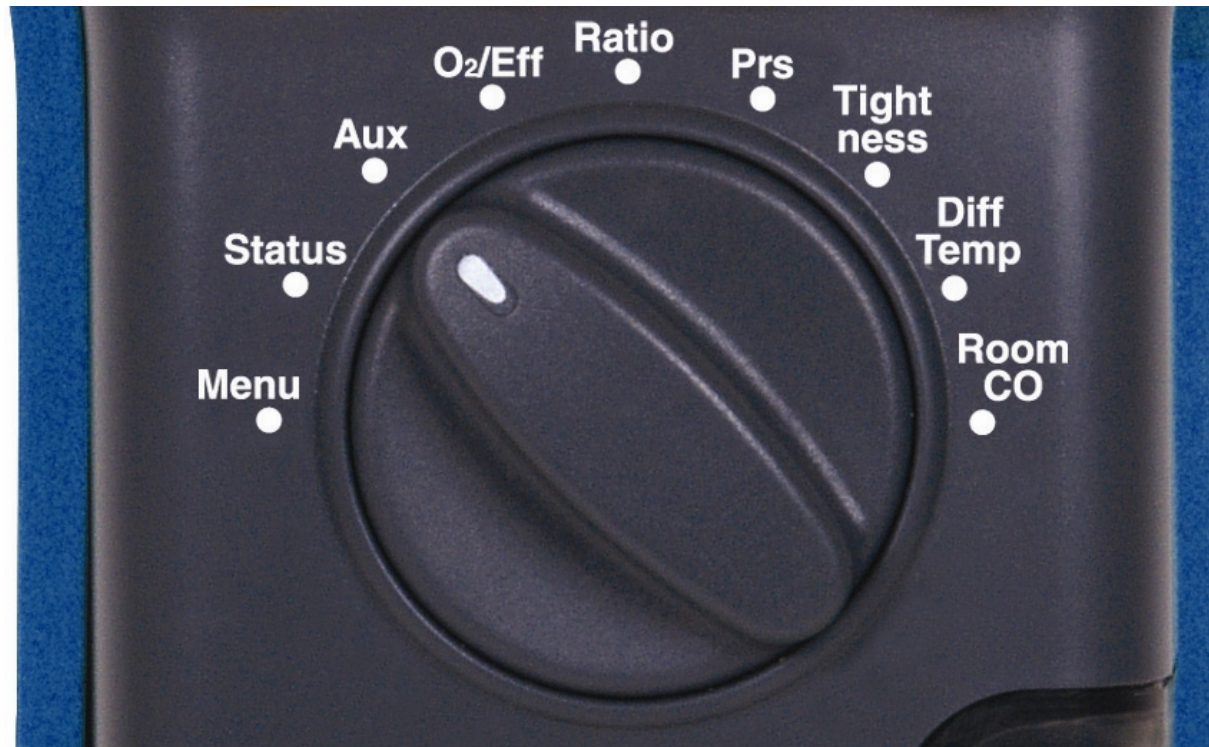

Kane International Ltd

KANE425 Kit includes...



- ✓ KANE 425 Analyser
- ✓ Flue probe
- ✓ Infra-red printer
- ✓ Pressure hose with adapters (x 2)
- ✓ Clamp-on pipe probes (x 2)
- ✓ Surface temperature probe (x 1)
- ✓ Gas Leak Detector
- ✓ Rechargeable batteries (NiMH)
- ✓ 240v fast charger/mains adapter
- ✓ 12v in-vehicle charger
- ✓ Carry case
- ✓ Traceable calibration certificate

Kane International Ltd

What's inside a KANE425?

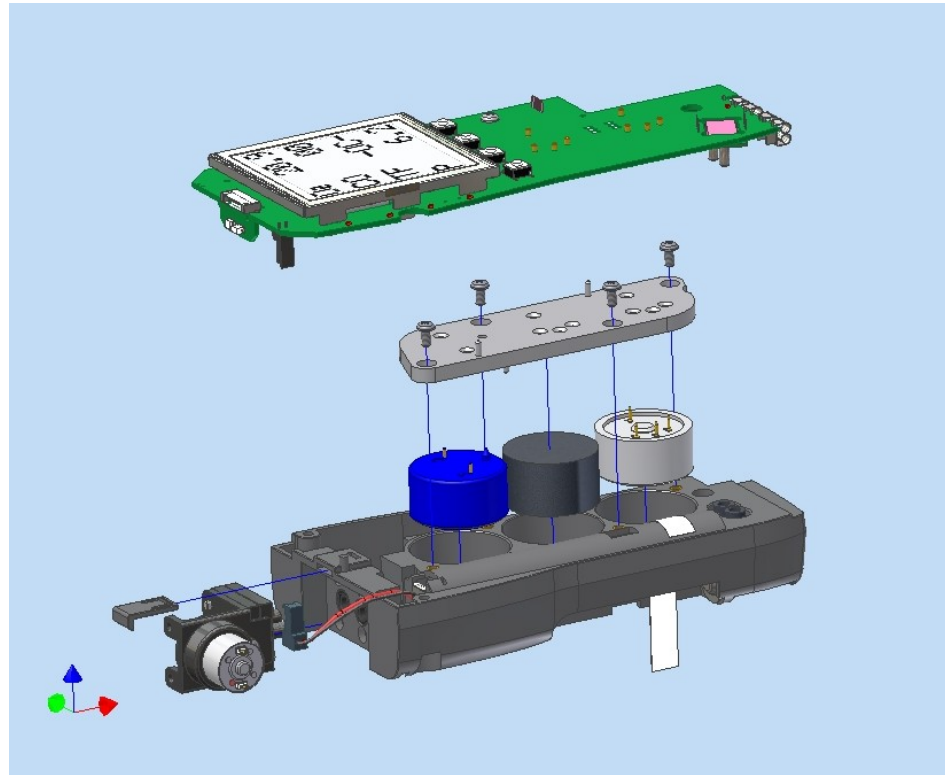

N.B. It can't measure ambient carbon dioxide, (CO_2)

Kane International Ltd



Kane International Ltd

KANE425 Connections

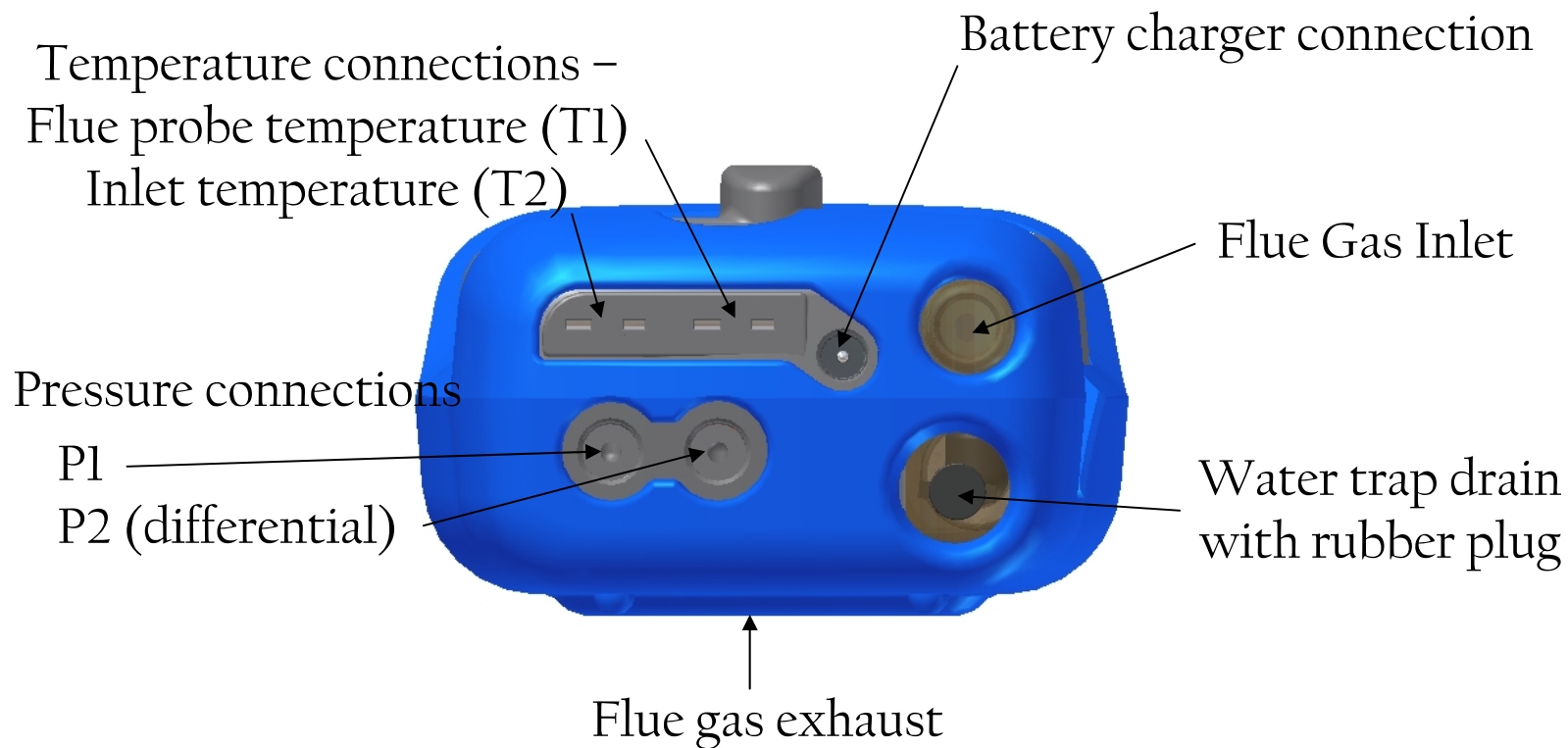

Kane International Ltd

1. Batteries

- Fitted with 4 x AA “Duracell” alkaline batteries
 - Typically last for 12 hours with pump running
- Kit includes...
 - 4 x NiMH rechargeable batteries
 - 240 volt mains charger; can “top-up” or “fully” charge
 - 12v in-vehicle charger; can “top-up” or “fully” charge

N.B. Fully charged NiMH batteries only show 65% but will still last for 12 hours with pump running

2. Before using the analyser...

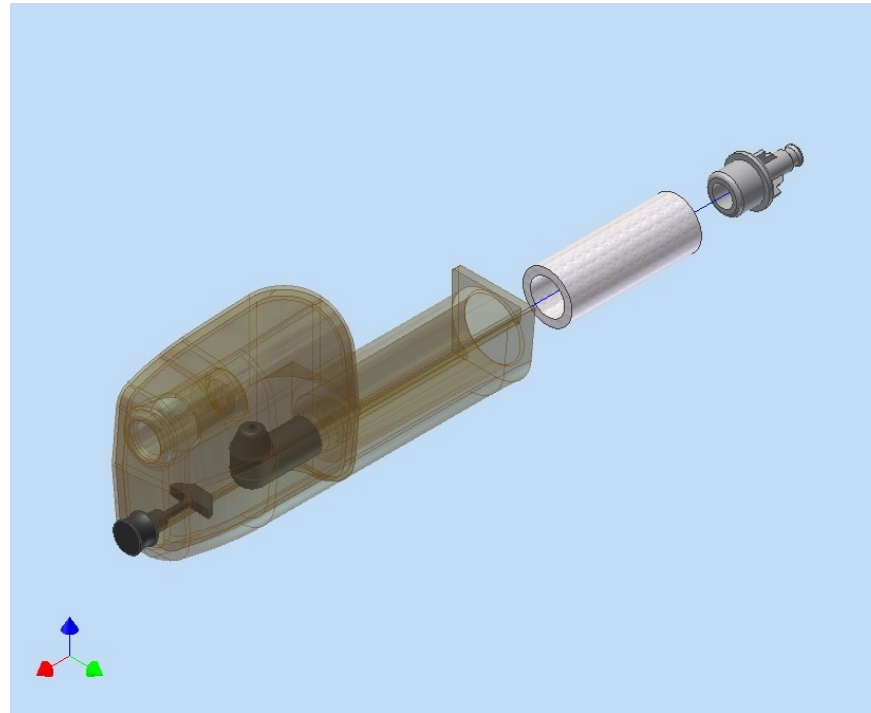

- Is the water trap empty?
- Is the particle filter clean?
- Is the water-trap drain plug fitted correctly?

Kane International Ltd

Connecting the flue probe

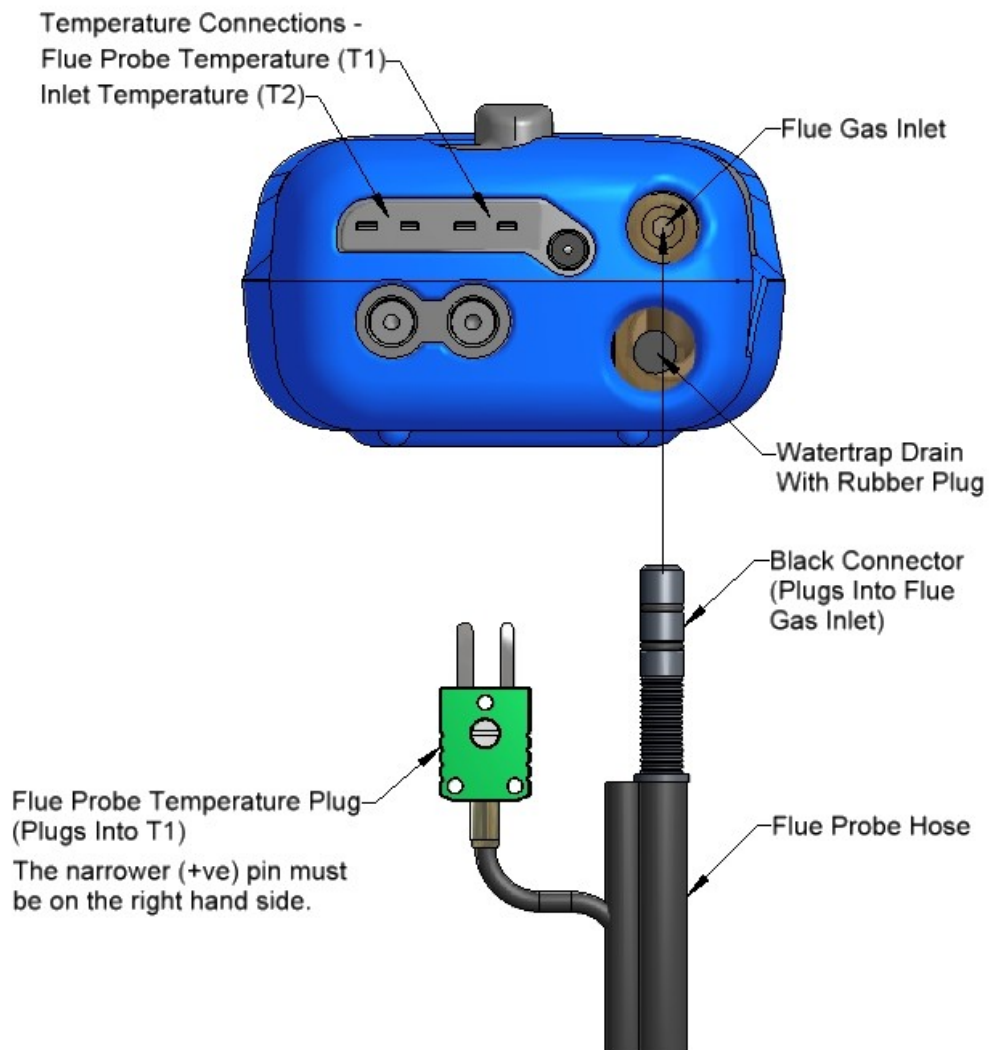

2.1 Fresh air purge

- Position the flue probe in fresh air
- Press 
- The pump starts and the analyser auto-calibrates for approximately 30 seconds. When complete...
- Select “Ratio” on the dial
 - In fresh air the CO reading should be zero
- Select “O₂/Eff” on the dial
 - In fresh air the O₂ reading should be 20.9% ± 0.1%

2.2 Status display

BAT	90
13:26:29	
03/05/06	
CAL	183

- Replace alkaline batteries if < 10%
- Recharge NiMH batteries if < 20%
- Current time – reset via “Menu”
- Current Date – reset via “Menu”
- Shows the number of days until next calibration is due. Counts down from 190 days for CORGI

Kane International Ltd

3. Using the Function Buttons

On/Off

ON/OFF

Turns the analyser
ON / OFF

Pump

PUMP

Turns the pump
ON / OFF



BACKLIGHT

Switches backlight
and torch light
ON / OFF

Send

SEND

Send readings to
printer
(or to PC via optional Bluetooth)

Send readings to
memory
(Hold button down to 2+ secs)

4.1 Combustion Tests

- Check the water trap including drain plug
- Connect the flue probe
- Auto-calibrate the analyser in fresh air
- Check O₂, CO readings and “Status” display
- Ensure the analyser is set for the correct fuel
- Insert the tip of the flue probe into the centre of the flue
- The readings should stabilise in 30 seconds

Kane International Ltd

Domestic Hot Water Boiler

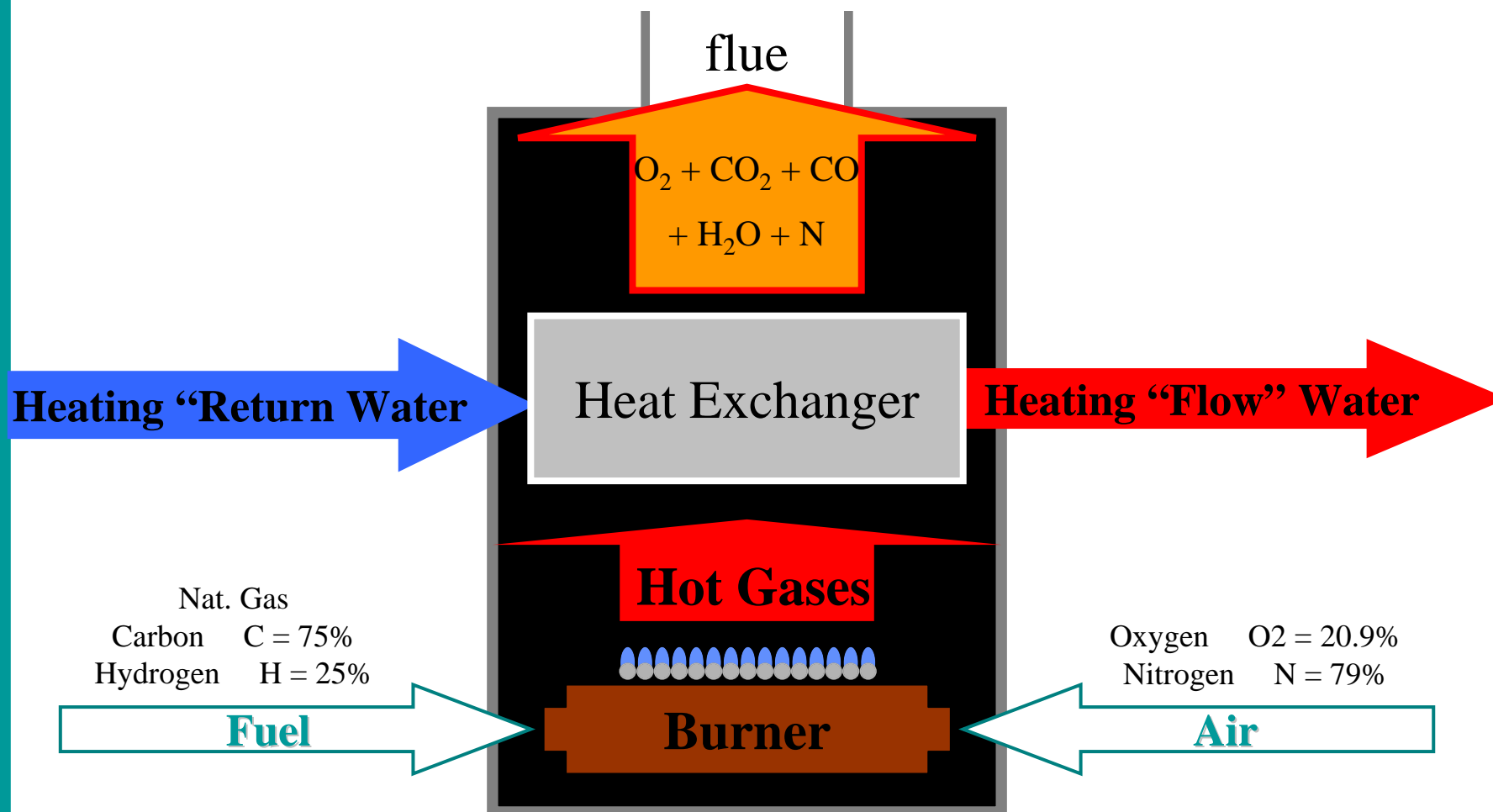

Kane International Ltd

RATIO display

NAT	GAS
R	0.0004
CO	37
CO₂	9.0

- Select other fuels via “Menu”
- CO/CO₂ Ratio
- Carbon Monoxide (ppm)
- Carbon Dioxide (%)

Kane International Ltd

O₂/EFF display

O2	5.1
TF	69.2
TI	18.7
Ef C	97.8

- Oxygen left after combustion.
Reads 20.9% in fresh air.
- Flue temperature (°C)
- Inlet temperature (°C)
- Condensing boiler efficiency
Can be changed via “Menu”

Kane International Ltd

AUX display

O2	5.1
CO	37
13:26:29	
BAT	90

- This is the default AUX (auxillary) display

The AUX display can be customised via MENU / SCREEN / AUX.

The parameters on lines 1, 2, 3 and 4 can be set independently.

They remain the AUX parameters until changed by the user.

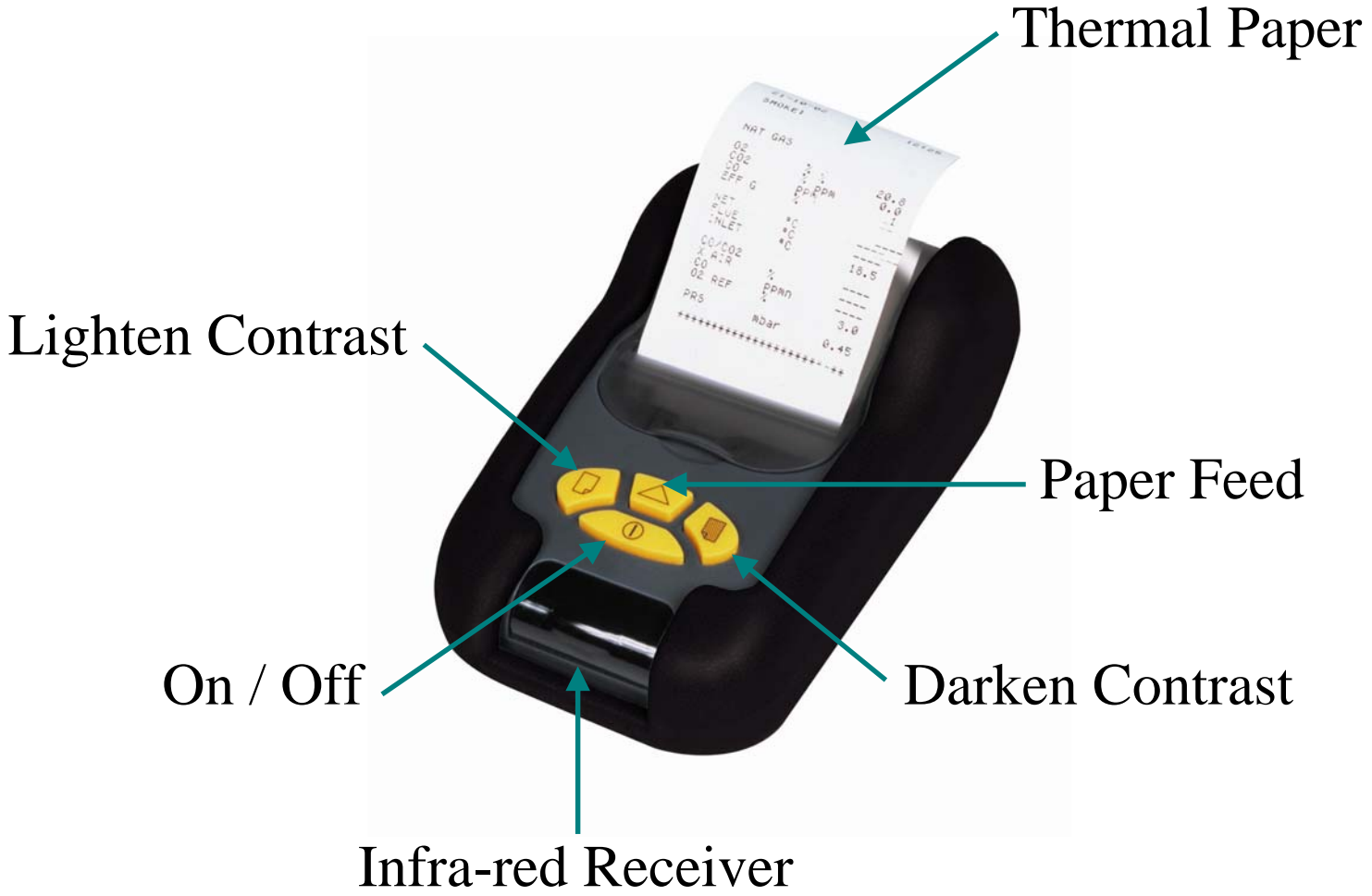

Kane International Ltd

Infra-red Printer



Printing a Combustion Test

A “live” combustion test can be printed if the rotary switch is in the “Ratio”, “O₂/Eff” or “Aux” position

- Switch the printer on, point the top of the analyser at the front of the printer, then press 
- The display will say “Printing”. Keep the analyser and printer inline until the printout has finished
- To abort a printout press  again

Kane International Ltd

Combustion Printout

```
K425 1.0
CORGI
s/n 001706001

DATE      03/05/06
TIME      13:24:28

COMBUSTION
.....
FUEL      NAT  GAS
O2 %      5.1
CO2 %     9.0
CO PPM    37
FLUE °C   69.2
INLT °C   18.7
NETT °C   50.5

EFF (C)   97.8
LOSSES    2.2
XAIR %    32.2

CO/CO2    0.0004
PRS mBAR  -0.01

.....
Customer
.....
Appliance
.....
Ref.
.....
```

Logging a Combustion Test

A “live” combustion test can be logged if the rotary switch is in the “Ratio”, “O₂/Eff” or “Aux” position

- Press  for 2+ seconds
- The top line of the display briefly displays “LOG XX”
- The memory can store up to 99 Combustion Reports
- Logged Combustion Reports can be viewed/printed via “Menu”

4.2 Pressure test

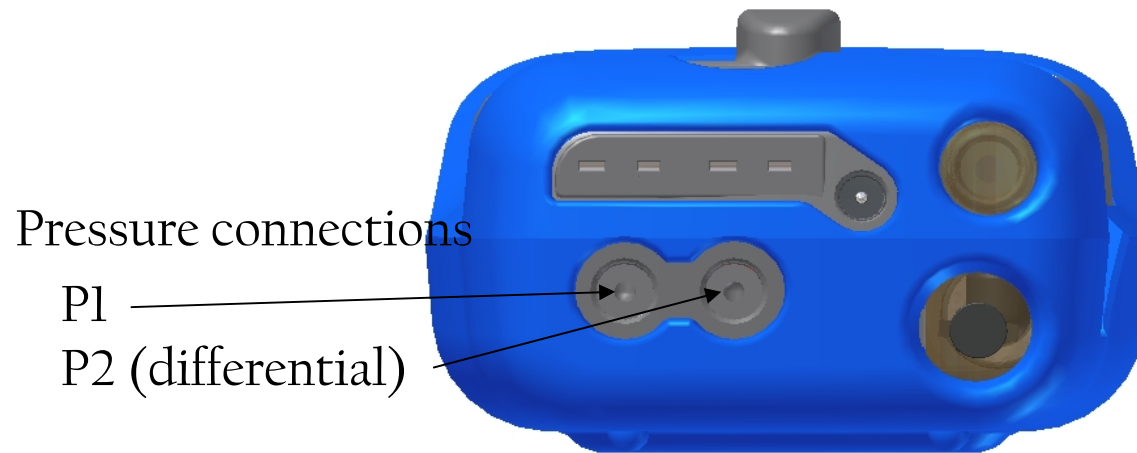

4.2 Pressure test

- Select “Prs” on the rotary switch. The pump stops.
- Press **Pump** to auto-zero the pressure sensor

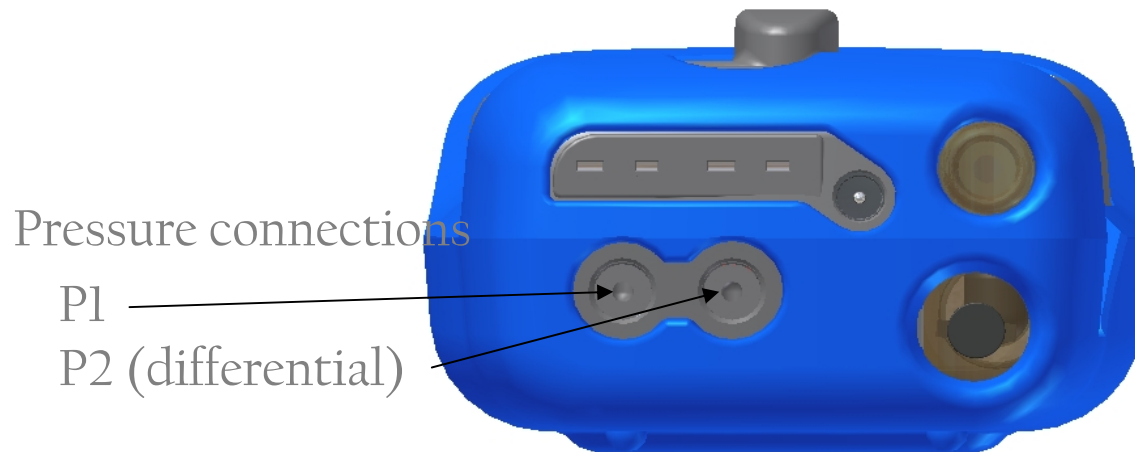

4.2 Pressure test

- Select “Prs” on the rotary switch. The pump stops.
- Press **Pump** to auto-zero the pressure sensor

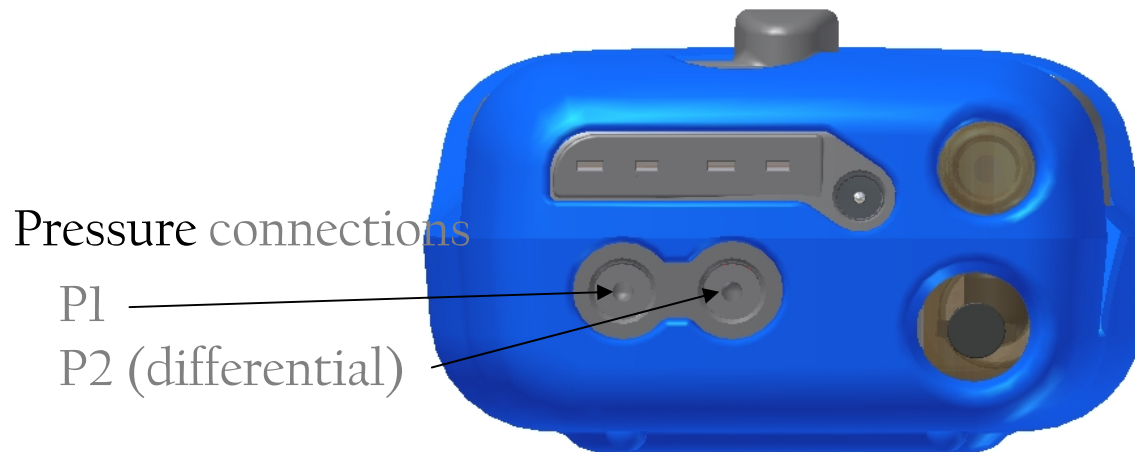

- Connect to P1 for single pressure or P1 and P2 for differential

Kane International Ltd

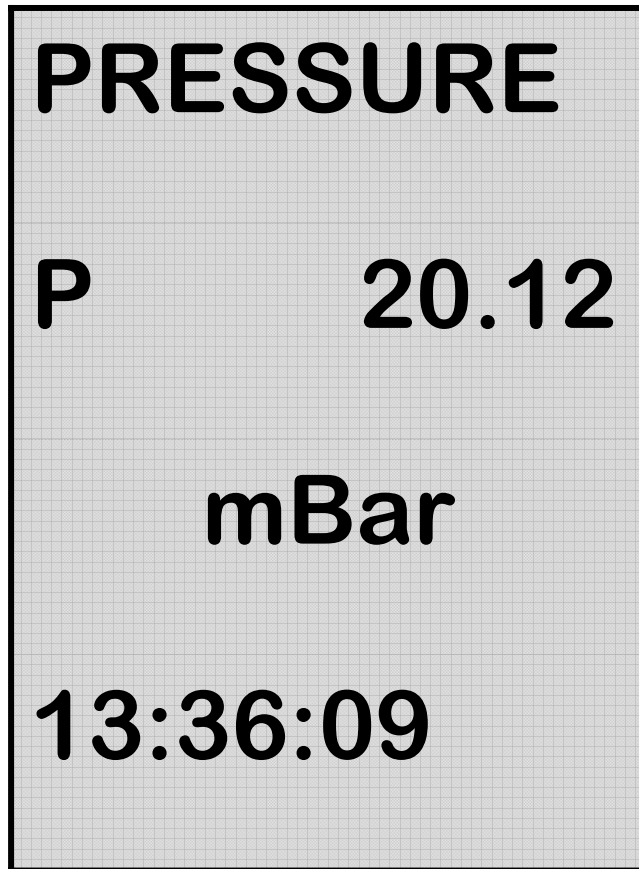

PRS display



- Pressure readings can be smoothed, (damped) if required
- Low or high resolution readings can be selected via “Menu”
- Units can be changed via “Menu”
- Displays time to enable manually timed tests

Kane International Ltd

Printing/Logging a Pressure Test

- To print a pressure test press 
- To log a pressure test press  for 2+ seconds
- The top line of the display briefly displays “LOG XX”
- The memory can store up to 20 Pressure Reports
- Logged Pressure Reports can be viewed/printed via “Menu”

Kane International Ltd

Pressure Printout

```
K425 1.0
CORGI
s/n 001706001

PRESSURE
.....

LOG          02
TIME 13:36 03/05/06

PRS  mBAR    20.12

.....
Customer
.....
Appliance
.....
Ref.
.....
```

4.3 Let-by and Tightness Test

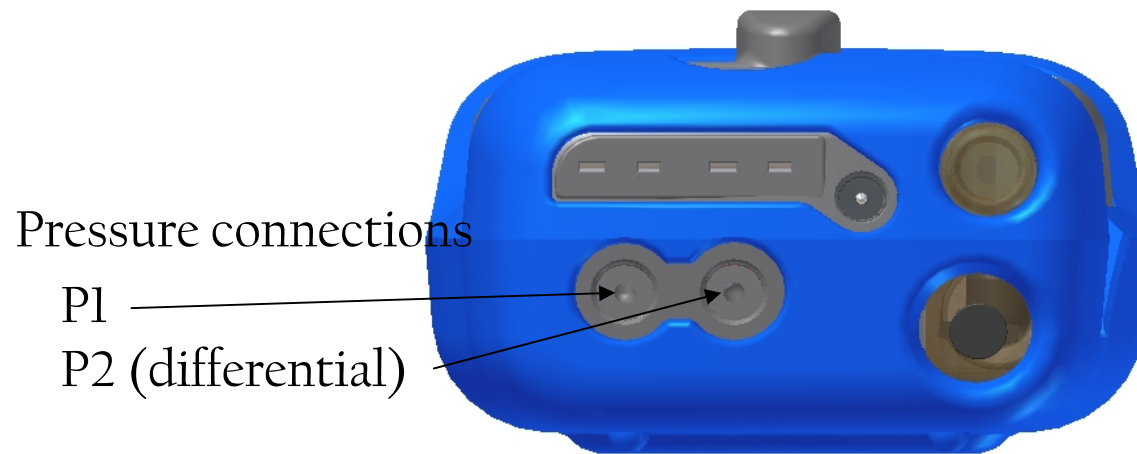

4.3 Let-by and Tightness Test

- Select “Tightness” on the rotary switch. The pump stops.
- Press **Pump** to auto-zero the pressure sensor

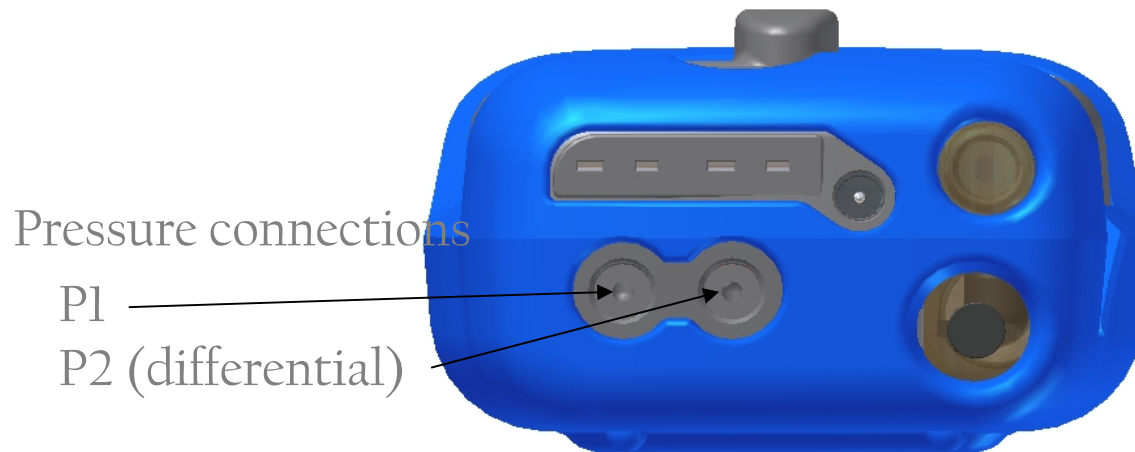

4.3 Let-by and Tightness Test

- Select “Tightness” on the rotary switch. The pump stops.
- Press **Pump** to auto-zero the pressure sensor

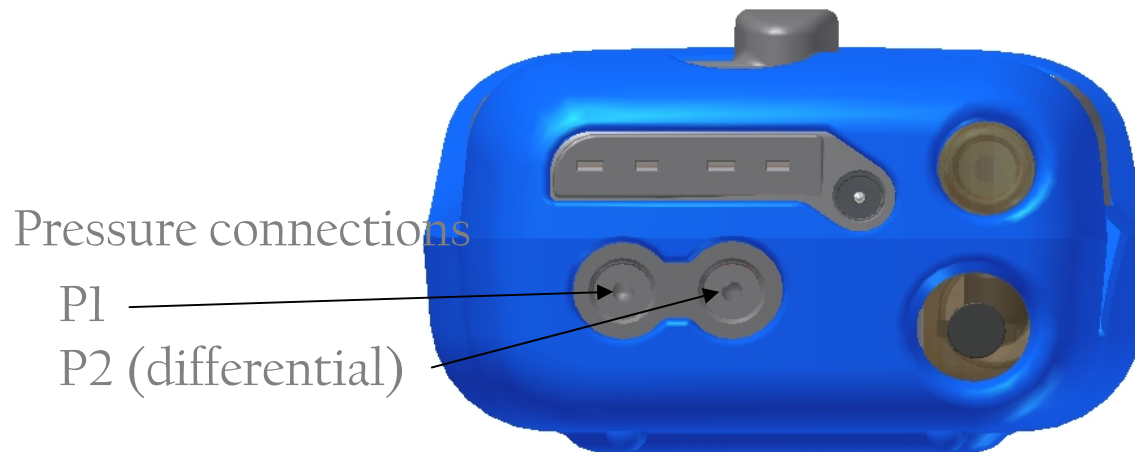

- Connect from P1 to test point

4.3 Let-by and Tightness tests

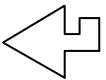
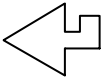
- Select “Tightness” on the rotary switch
- The pump stops automatically
- Press  to auto-zero the pressure sensor
- The display shows “LET BY ?”
- Use ∇ , Δ and  to select Yes or No
- If Yes is selected, set the let-by pressure then press  to start the test

Kane International Ltd

LET-BY display

LET BY	
P1	10.15
P2	10.15
TIME	59

- Pressure at start of let-by test
- Real time pressure reading
- Let-by default time is 1 minute.
Can be changed via “Menu”

STABILISATION display

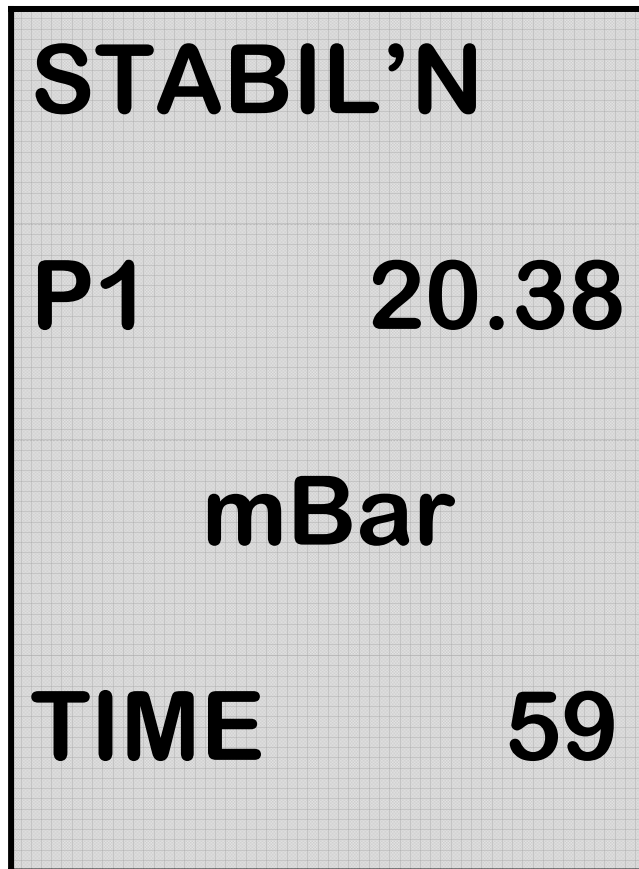

- The let-by test is auto-logged. Adjust gas pressure and press  to start the stabilisation test
- Real time pressure reading during the stabilisation test
- Pressure units
- Stabilisation default time is 1 min. Can be changed via “Menu”

Kane International Ltd

TIGHTNESS test

TIGHTN'S	
P1	20.34
P2	20.34
TIME	119

- If the stabilisation test passes, press  to start the tightness test
- Pressure at start of tightness test
- Real time pressure reading
- Tightness test default time is 2 min. Can be changed via "Menu"

Kane International Ltd

When complete the display will show...

LOG	01
P1	20.34
P2	20.25
PRINT	↓

- The tightness test is stored in the memory as this log number
- Pressure at start of tightness test
- Pressure at end of tightness test
- Press  to print the let-by and tightness test

Kane International Ltd

Tightness Test Printout

```
K425 1.0
YOUR COMPANY NAME &
PHONE NUMBER HERE

LOG          04
TIME 11:53 15/05/06

Let By Test
.....

PRS_1 MBAR    10.12
PRS_2 MBAR    10.11
LET BY MINS   1:00

Tightness Test
.....

PRS_1 MBAR    20.12
PRS_2 MBAR    20.10
ΔPRS MBAR     -0.02
STABIL'N MINS 1:00
TIGHTN'S MINS 2:00

.....
Customer
.....
Appliance
.....
Ref.
.....
```

Kane International Ltd

4.4 DIFF TEMP display

TEMP	
T1	70.9
T2	67.1
ΔT	3.8

- Pump switches off when dial is moved to “Diff Temp”
- Use the T1 connection for the flow temperature sensor
- Use the T2 connection for the return temperature sensor
- Real time temperature difference (ΔT)

Kane International Ltd

Surface temperature probes



- Pipe clamp probes (type K)

Kane International Ltd

Differential Temperature Printout

```
K425 1.0
CORGI
s/n 001706001

DIFF TEMP
.....

LOG          03
TIME 13:05 03/05/06

T1    °C    70.9
T2    °C    67.1
ΔT    °C    3.8

.....
Customer
.....
Appliance
.....
Ref.
.....
```

Kane International Ltd

Surface temperature probes

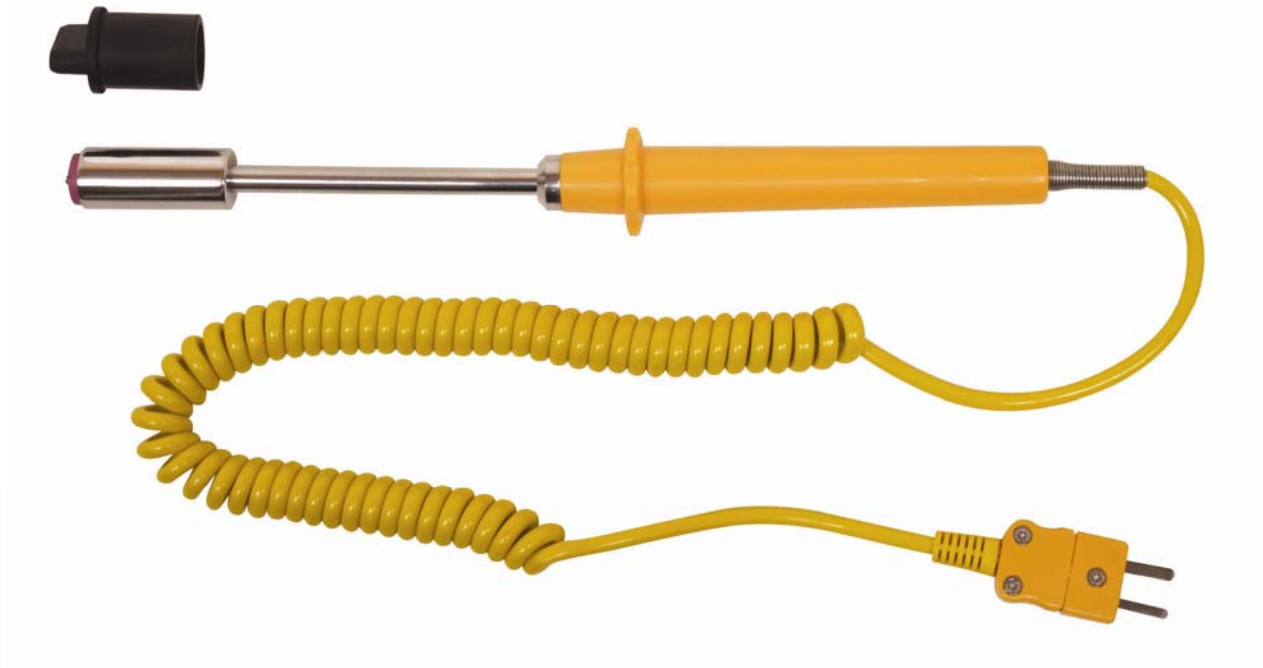

- Heavy duty surface probe (type K)

Kane International Ltd

4.5 ROOM CO display

ROOM	CO
CO	11
TEST	12
LOG	01

- Select “Room CO” on the dial then press **Pump** to start the test
- Real time CO reading (ppm)
- Test 00 = initial reading,
Test 15 = final reading
- The “Room CO” test is stored in the memory as this log number

Kane International Ltd

ROOM CO Printout

```
K425 1.0
CORGI
s/n 001706001

ROOM CO TEST
.....

LOG          01
TIME 14:19 03/05/06

TEST          CO ppm
0             00
1             00
2             00
3             00
4             00
5             00
6             00
7             10
8             01
9             00
10            00
11            00
12            11
13            09
14            04
15            00
.....
MAXIMUM CO   11
.....
Customer
.....
Appliance
.....
Ref.
.....
```

Kane International Ltd

Using AUX display for Room CO

O2	20.9
CO	07
13:26:29	
BAT	90

- Reads 20.9% in fresh air
- Monitor and record the CO reading as per BS7967
- Use the clock to manually time the CO test
- Ensure batteries have sufficient charge to complete the test

Kane International Ltd

5. Using the MENU

Select “Menu” on the rotary switch and navigate using...

 = Scroll up

 = Scroll down

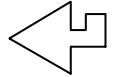
 = Enter

Kane International Ltd

5. Using the MENU

Select “Menu” on the rotary switch and navigate using...

 = Scroll up

 = Scroll down

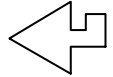
 = Enter

The main menu includes...

SETUP
PRESSURE
REPORT
SCREEN
SERVICE

Kane International Ltd

Using MENU / SETUP

MAIN MENU	SUB MENU	OPTIONS / COMMENTS
SETUP	SET FUEL	NAT GAS, LIGHT OIL, PROPANE, BUTANE, L.P.G., PELLETS (wood pellets)
	N←C→G	EfC = condensing boiler efficiency EfN = nett efficiency, EfG = gross efficiency Always defaults to EfC on start-up
	SET TIME	HH:MM:SS format. E.g. 7pm = 19:00:00
	SET DATE	DD/MM/YY format
	EXIT	

Kane International Ltd

Using MENU / PRESSURE

MAIN MENU	SUB MENU	OPTIONS / COMMENTS
PRESSURE	SMOOTH	OFF = normal response. ON = damped response Always defaults to OFF on start-up
	RESOLVE	LOW = 0.01 mBar res., HIGH = 0.001 mBar res. Always defaults to LOW on start-up
	PS UNITS	mBar, mmH ₂ O, Pa, kPa, PSI, mmHg, hPa, InH ₂ O
	TIME	LET BY = Set duration of let-by test in mins STABIL'N = Set duration of stabilisation in mins TIGHTN'S = Set duration of tightness test in mins
	EXIT	

Kane International Ltd

Using MENU / REPORT

MAIN MENU	SUB MENU	OPTIONS / COMMENTS
REPORT	COMB'N	Stored combustion tests. (Up to 99 logs)
	PRESSURE	Stored pressure tests. (Up to 20 logs)
	TIGHTN'S	Stored let-by/tightness tests. (Up to 20 logs)
	TEMP	Stored diff. temperature tests. (Up to 20 logs)
	ROOM CO	Stored room CO tests. (Up to 20 logs)
		All reports have VIEW, DEL ALL, EXIT options

Kane International Ltd

Using MENU / SCREEN

MAIN MENU	SUB MENU	OPTIONS / COMMENTS
SCREEN	CONTRAST	Factory setting is 04
	AUX	Enables the user to customise the parameters on the AUX display: LINE 1, LINE 2, LINE 3, LINE 4, EXIT
	HEADER	Enables the user to customise the printout header, 2 x lines, 20 x characters per line: HEADER 1, HEADER 2, EXIT
	EXIT	

Kane International Ltd

MENU / SERVICE

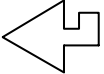
MAIN MENU	SUB MENU	OPTIONS / COMMENTS
SERVICE	CODE	Password protected for authorised service agents only. Leave set to 0000 Press  four times to exit the SERVICE menu

Symbols used on the display

P = Pressure

R = CO/CO₂ ratio

λ = Excess air

▲ = losses %

TF = Flue temperature

TI = Inlet temperature

ΔT = Nett temperature

Kane International Ltd

Symbols used on the display

- EfG = Gross combustion efficiency
- EfN = Nett combustion efficiency
- EfC = Condensing boiler combustion efficiency
- PO- = Pump off
- O>- = Oxygen greater than 18%,
(CO₂ and efficiency calculations disabled)
- OC- = Open circuit temperature input
- CAL = Number of days before calibration is due

Additional information

Other sections in the KANE425 manual include...

- 6. Using the KANE425 as a thermometer and pressure meter
- 7. Measuring flue gases
- 8. Analyser problem solving
- 9. Analyser annual recalibration and service
- 10. Analyser specification
- Appendix 1 – Main parameters

Gas Leak Detection

- Plug the gas leak detector into the side of the analyser
- The pump will stop and the display shows GAS LEAK DETECT.
- Switch on the gas leak detector.
- The gas leak detector may take up to 30 seconds to stabilise.
- The unit will detect leaks as low as 50ppm of methane.