

Lanemark TX series high efficiency, small diameter immersion tube tank heating systems offer end users the most cost effective method of heating process liquids which are used in many areas of industry.

Specific advantages compared with alternative tank heating methods –

- Low operating costs – operating efficiencies of
 - ≥80% gross calorific value
 - ≥90% net calorific value
- TX small diameter immersion tube heat exchangers occupy minimal tank space. This enables smaller tanks to be used for new plant designs and allows simple replacement of other heating systems for retrofit applications. TX immersion tubes can be configured in multi-pass shapes to ensure that they remain well clear of internal tank fittings or processing areas.
- Tank heat input and immersion tube performance calculations are easily carried out using Lanemark's dedicated design software.
- Heat exchangers can be configured to fit rectangular tanks and horizontal or vertical cylindrical tanks utilising helical coil heat exchanger arrangements where necessary.
- Induced draught combustion air arrangement allows multiple burner systems to be connected to a common flue, retaining individual burner control.
- Simple heat exchanger installation requires only two pipe flange drillings, usually in one tank wall.
- Operates with low gas supply pressures.
- Firing into rubber lined or fibre glass tanks is permitted due to low initial heat exchanger surface temperatures at tank connection.
- Fully compatible with Lanemark TRX burner systems so that they may be incorporated into schemes where multiple TRX/TX burner arrangements are required.

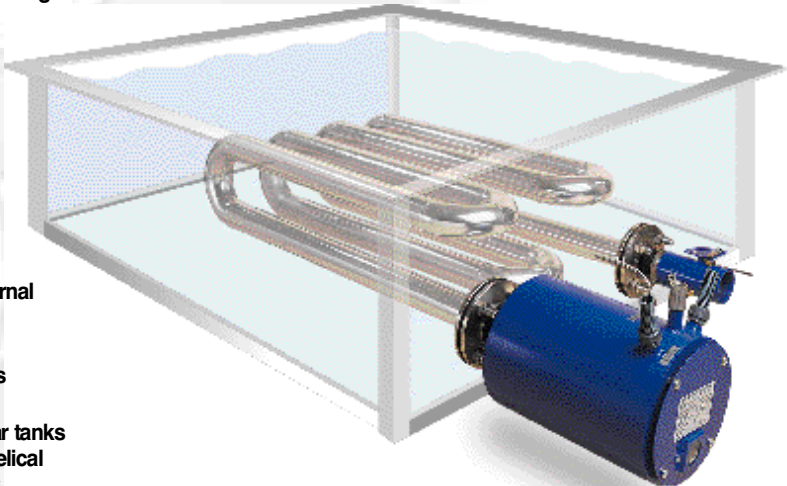

Model	Tube Size	Maximum Heat Input	
TX15	1½" (40mm)	45kW	(150,000 Btu/h)
TX20	2" (50mm)	80kW	(275,000 Btu/h)
TX25E	2½" (65mm)	140kW	(475,000 Btu/h)
TX30	3" (75mm)	220kW	(750,000 Btu/h)
TX40	4" (100mm)	440kW	(1,500,000 Btu/h)
TX60	6" (150mm)	730kW	(2,500,000 Btu/h)

Typical Applications

- **Product finishing**
(metal parts, steel strip, wire products, etc.)
 - Pre-treatment and treatment processes including:
 - alkali/caustic degreasing
 - phosphating
 - hot water rinsing
 - aluminium etching
 - anodising
 - borax and lime coatings
 - Dip tanks
 - Spray systems
 - Hot water supply systems
- **Cleaning**
(industrial washing machines)
 - Plastic crate washers
 - Parts washers
 - Bottle washers
- **Food and Drink Production**
 - Hot water tanks
 - Mini brewery wort coppers
 - Cleaning in place (CIP) tanks
 - Animal scalders
 - Blanchers

TX burners conform with European Standards EN 676 and EN 746 as appropriate and are pre-wired and tested prior to despatch.

Specifications

A modular Lanemark TX immersion tube burner system includes a cylindrical burner assembly built to withstand typical tank heating operating environments, a compact monobloc valve gas train, burner controls mounted in a

protective control box (which can include a digital temperature controller), exhaust damper and an exhaust fan which can be coupled to multiple TX/TRX burner installations.

	✓ Standard equipment	● Options
Fuels	✓ Natural gas	● Propane
Control voltages	✓ 230V	● 110V
Exhaust fan electrical supplies	✓ 400V/3ph/50Hz	● 230V/1ph/50Hz
Flame sensing	✓ Flame electrode	● UV scanner
Heat output control options	✓ On/off or High/low	● Modulating

DIMENSIONS & PERFORMANCE

TX TANK HEATING SYSTEMS

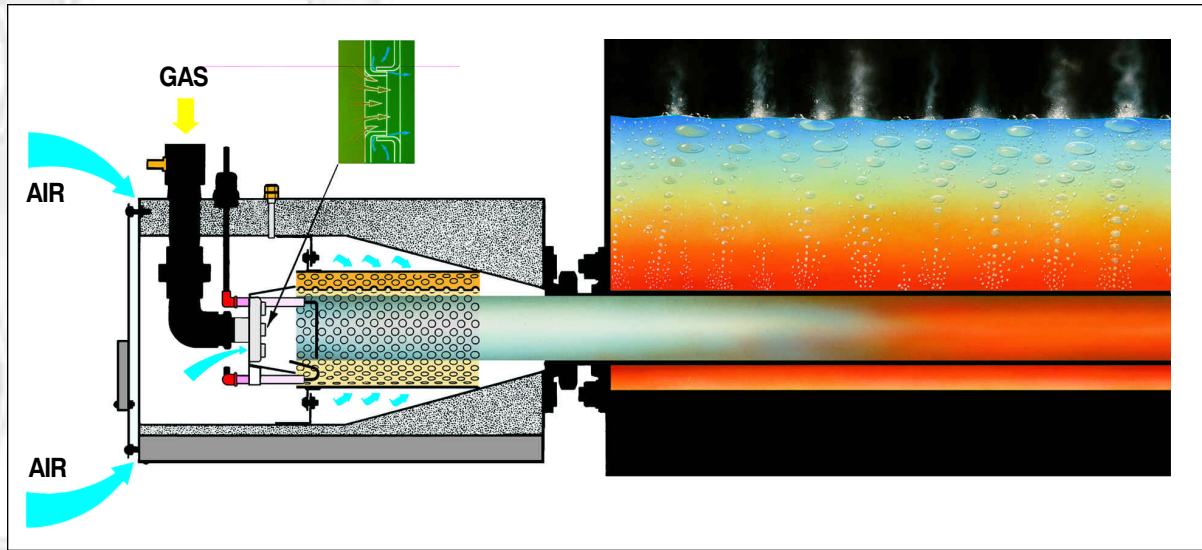

MODEL NO.	DIMENSIONS							
	A	B	C	D	E	F	G	H
TX15/20	220	150	40	305	75	½" BSP	160	12
TX25E/30	295	225	50	450	75	1" BSP	210	25
TX40	295	300	50	500	75	1½" BSP	230	25
TX60	405	320	120	625	75	2" BSP	305	35

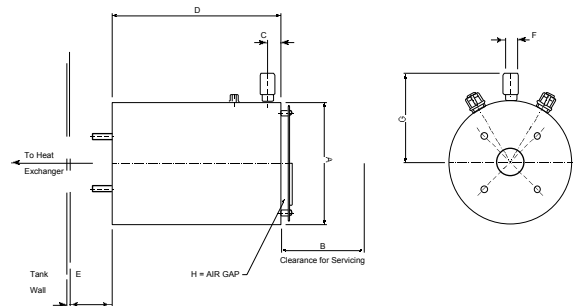

All dimensions are in mm, except where stated.



LANEMARK
BurnerCare

All TX burners benefit from Lanemark's BurnerCare customer support. BurnerCare services include burner system commissioning/start-up, supply of spare parts and system training. BurnerCare will provide a contract service plan and a rapid response facility, designed to ensure the continued and reliable operation of Lanemark equipment worldwide.

Additional Burner Products *(See individual Data Sheets for full details)*

Also available from Lanemark is the TRX range of low cost small "packaged" tank heaters ideal for smaller scale operations and the FD range of high turn-down process air heating oven and dryer burner products.

All illustrations are for guidance only. For reasons of continuous development, Lanemark International Limited reserves the right to alter specifications without prior notice.

LANEMARK
INTERNATIONAL

Lanemark House, Whitacre Road, Nuneaton, Warwickshire CV11 6BW United Kingdom

Tel: +44 (0) 1203 352000 Fax: +44 (0) 1203 341166

E-mail: info@lanemark.com Web site: <http://www.lanemark.com>



REGISTRATION NO. 7237

